



## Installation Instructions

# ControlLogix Redundant Power Supply

Catalog Numbers 1756-PA75R/A (85-265V AC Redundant Power Supply),  
1756-PB75R/A (19-32V DC Redundant Power Supply)

Use this publication as a guide when installing the ControlLogix™ 1756-PA75R/A and 1756-PB75R/A power supplies. These supplies may only be used with Series B ControlLogix chassis.

To:	See page:
See a Description of the Redundant Power Supply	2
See an Overview of the Installation Process	2
See the European Communities (EC) Directive Compliance	3
Prepare for Installation	4
Identify the Components of a Redundant Power Supply System	4
Recognize Redundant Power Supply Physical Features	5
Use System Set-up Recommendations	6
Allow Sufficient Mounting Space	7
Install Your Redundant Power Supply	8
Ground Your Redundant Power Supply	10
Connect the Cable to the Redundant Power Supply and the Chassis Adapter Module	11
Connect Solid State Relay	12
Connect Power	13
Route Line Power and Cables	14
Remove the Protective Label	15
Activate the Redundant Power Supply System	15
Troubleshoot with the Status Indicators	16
Replace a Redundant Power Supply	17
See 1756-PA75R/A and 1756-PB75R/A Specifications	18
See Additional Information and Notes	19
See Hazardous Location Information	19

## Description of the Redundant Power Supply

These supplies are part of a redundant power supply system that provides additional uptime protection for a chassis used in critical applications. The two remotely-mounted supplies are designed to share the current required by the chassis. They are available in AC (1756-PA75R/A) and DC (1756-PB75R/A) versions that can be mixed or matched when used in tandem.

In the event of a failure by one redundant power supply, the remaining supply will accommodate the entire load of the chassis without disruption to chassis activity.

## Overview of the Installation Process

Follow these steps when installing and powering your Redundant Power Supply system.

1. Allow Sufficient Mounting Space
2. Install Your Redundant Power Supply
3. Ground Your Redundant Power Supply
4. Connect the Cable to the Redundant Power Supply and the Chassis Adapter Module
5. Connect Solid State Relay
6. Connect Power
7. Activate the Redundant Power Supply System

The steps are described in detail, along with other important information, throughout this installation instructions.

---

### ATTENTION



Electrostatic discharge can damage integrated circuits or semiconductors if you touch connector pins. Follow these guidelines when you handle the 1756-PA75R/A or 1756-PB75R/A.

- Touch a grounded object to discharge static potential.
- Do not touch the connector or connector pins.
- Do not touch circuit components inside the redundant power supply.
- If available, use a static-safe work station.
- When not in use, keep the redundant power supply in its static-shield packaging.

## European Communities (EC) Directive Compliance

If this product has the CE mark it is approved for installation within the European Union and EEA regions. It has been designed and tested to meet the following directives.

### EMC Directive

This product is tested to meet the Council Directive 89/336/EC Electromagnetic Compatibility (EMC) by applying the following standards, in whole or in part, documented in a technical construction file:

- EN 50081-2 EMC — Generic Emission Standard, Part 2 — Industrial Environment
- EN 50082-2 EMC — Generic Immunity Standard, Part 2 — Industrial Environment

This product is intended for use in an industrial environment.

### Low Voltage Directive

This product is tested to meet Council Directive 73/23/EEC Low Voltage, by applying the safety requirements of EN 61131-2 Programmable Controllers, Part 2 - Equipment Requirements and Tests. For specific information required by EN 61131-2, see the appropriate sections in this publication, as well as the Allen-Bradley publication Industrial Automation Wiring and Grounding Guidelines, publication 1770-4.1.

Open style devices must be provided with environmental and safety protection by proper mounting in enclosures designed for specific application conditions. See NEMA Standards publication 250 and IEC publication 529, as applicable, for explanations of the degrees of protection provided by different types of enclosure.

## Prepare for Installation

You need the tools shown below to install a ControlLogix redundant power supply.

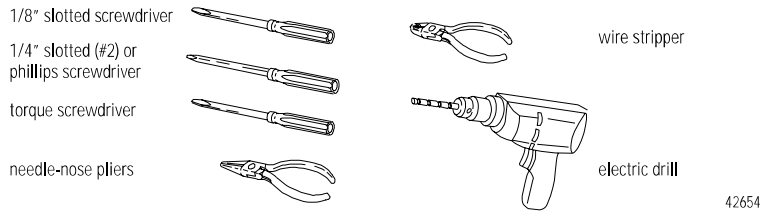

## Identify the Components of a Redundant Power Supply System

**Table A**  
**Redundant Power Supply System Components**

Catalog Number	Description	Quantity
1756-PA75R/A and/or 1756-PB75R/A	Redundant power supply	2
1756-CPR	Redundant power supply cables (Length = 0.91m [3ft])	2
1756-PSCA	Redundant power supply chassis adapter module	1
User-supplied <sup>1</sup>	Annunciator wiring (Maximum length = 10m [32.8ft])	2

<sup>1</sup> Optional user-provided annunciator wiring can be connected to the solid state relay for status and troubleshooting purposes. For more information, see pages 12 and 16.

The components are shown below in a typical system configuration:

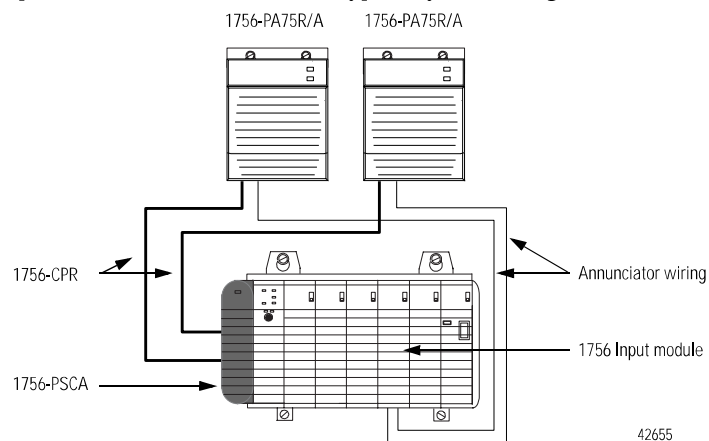

## Recognize Redundant Power Supply Physical Features

Your redundant power supply has multiple physical features as shown below.

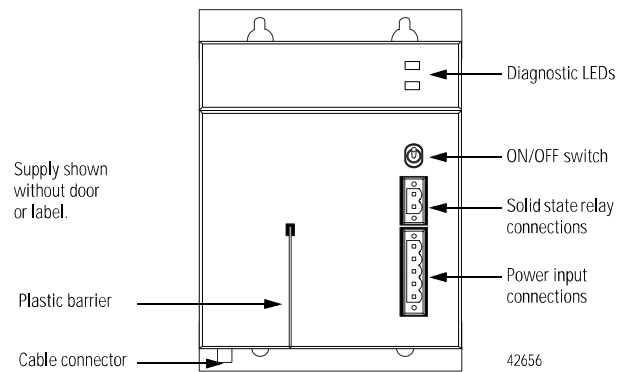

**Table B**  
**Redundant Power Supply Physical Features**

Physical Feature	Description
Plastic barrier	The barrier separates the input power cable from the annunciator cable.
Cable connector	The cable connector accommodates the 1756-CPR cable and connects power to the chassis. For more information, see page 11.
Diagnostic status indicators	There are two indicators: <ul style="list-style-type: none"> <li>• Power</li> <li>• Non-Red (Nonredundancy)</li> </ul> For more information on the status indicators, see page 16.
ON/OFF switch	Switch that turns the backplane power ON and OFF at the connected chassis. (Up is the ON position.)
Solid state relay connections	These contacts allow optional failure annunciation when wired to a standard input module. The solid state relay contacts are normally open, but held closed during normal operation. For more information on these connections, see page 12.
Power input connections	These connections allow you to wire input power to the redundant power supply. For more information on these connections, see page 13.

## Use System Set-up Recommendations

We recommend you use one of the methods shown below when setting up your redundant power supply system.

### Recommended Set-Ups for System Using One Chassis

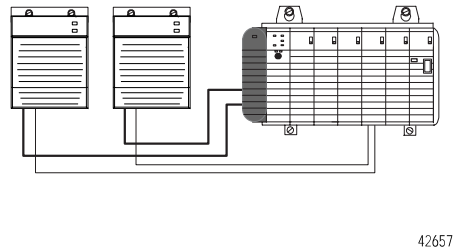
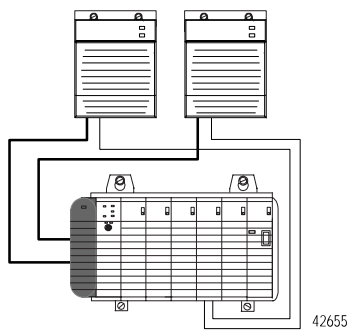

### Recommended Set-Ups for System Using Two Chassis

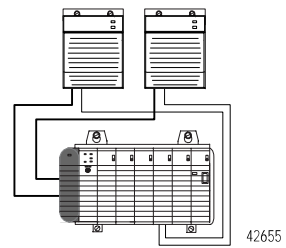
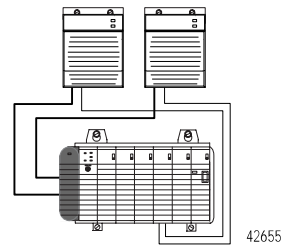
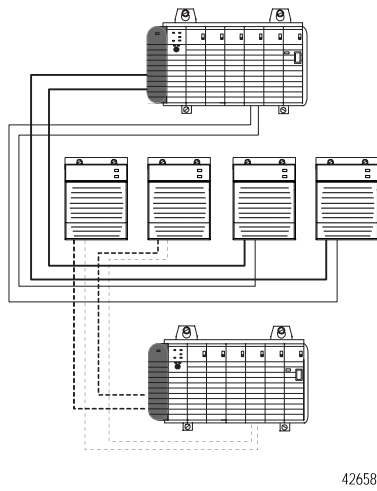

## Allow Sufficient Mounting Space

**IMPORTANT**

Make sure you meet these minimum spacing requirements:

- 10.2cm (4in) between redundant power supplies and cabinet housing the control system
- 2.55cm (1in) between redundant power supplies
- 15.3cm (6in) between chassis and heat source
- 5.1cm (2in) between wireway and top or bottom of chassis
- 5.1cm (2in) between wireway and power supply

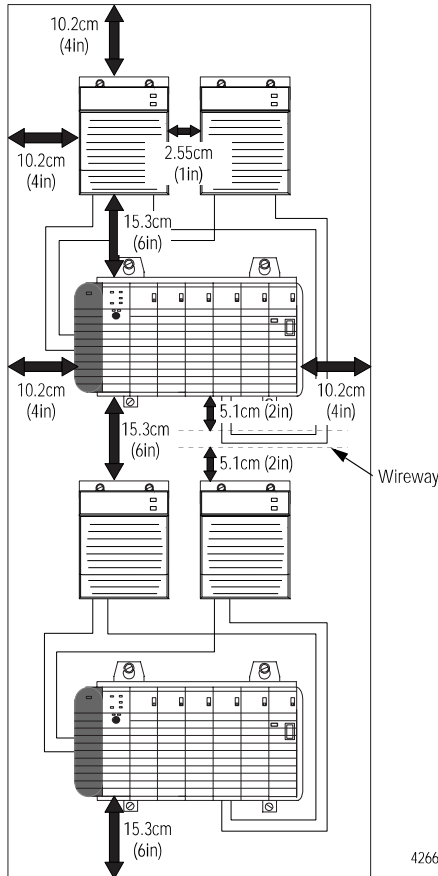

Table C lists the widths of each ControlLogix chassis type with a Redundant Power Supply Chassis Adapter module installed. Keep these widths in mind when mounting your chassis.

**Table C**  
Width of Chassis with Redundant Power Supply Chassis Adapter Module Installed

Catalog Number:	Total Width:
1756-A4	18.5cm (7.30in)
1756-A7	29.0cm (11.44in)
1756-A10	40.5cm (15.96in)
1756-A13	51.0cm (20.10in)
1756-A17	66.0cm (26.0in)

For more information on spacing requirements between chassis, see the ControlLogix Chassis Installation Instructions, publication number 1756-IN080.

## Install Your Redundant Power Supply

**ATTENTION**



Do not drill holes for a redundant power supply above installed equipment (e.g. chassis). Metal chips from drilling can damage the backplane and cause intermittent operation.

1. Use the mounting dimensions in the following diagram.

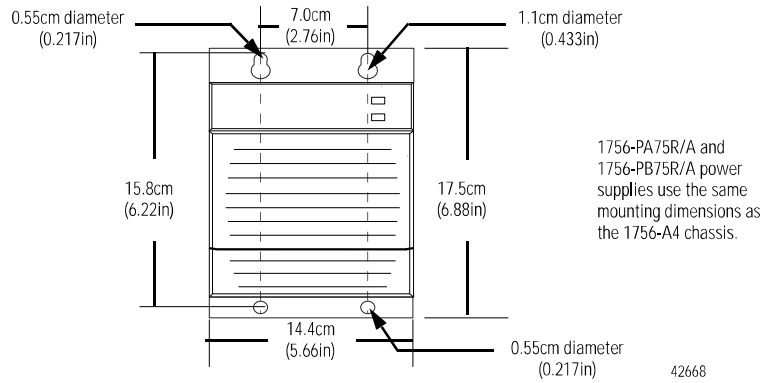

The 1756-PA75R/A and 1756-PB75R/A power supplies use the same mounting dimensions as the 1756-A4 chassis.

2. Drill holes in the back panel of the enclosure for redundant power supply mounting tabs.

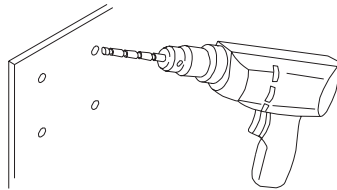

20288



3. Install the hardware for the top mounting tabs.

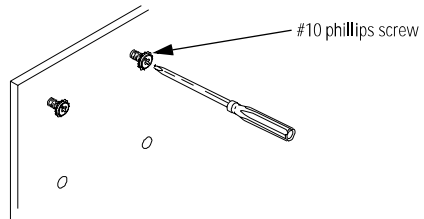

42664

4. Slide the redundant power supply over the installed screws and tighten them.

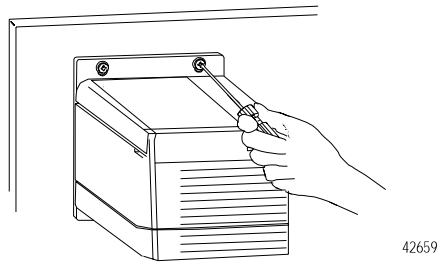

5. Install the remaining tab screw(s).

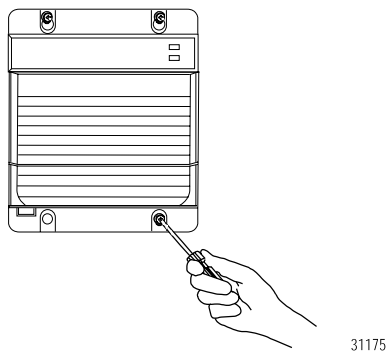

## Ground Your Redundant Power Supply

The figure below shows how to run functional and equipment protective earth ground connections from the chassis and power supplies to the ground bus.

For specific information on how to connect ground wiring to the redundant power supply, see page 13. For specific information on how to connect ground wiring to the chassis, see the ControlLogix chassis installation instructions, publication 1756-IN080.

We recommend the following:

- Use a ground bus to reduce the electrical resistance at the connection.
- Keep wire lengths as short as possible.
- Use 14 AWG 75°C wire for ground connections.

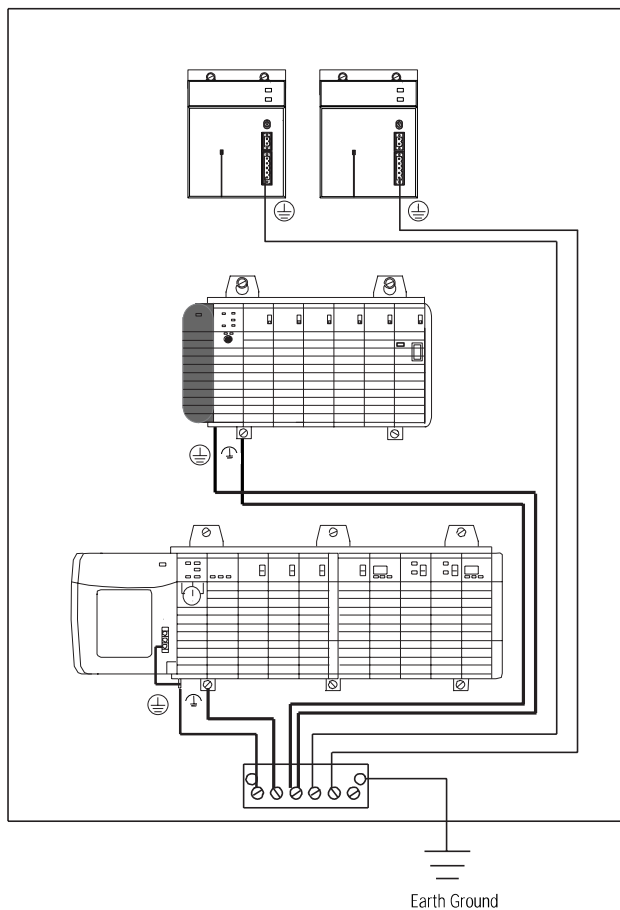

42661

## Connect the Cable to the Redundant Power Supply and the Chassis Adapter Module

Use the 1756-CPR cable to connect your redundant power supply to the chassis adapter module. The 1756-CPR cable uses two female ends to connect to male connectors on the redundant power supply and the chassis adapter module.

### ATTENTION



Make sure the redundant power supply is turned off before connecting the 1756-CPR cables to the chassis adapter module or the power supply.

1. Leave a minimum of 4 in (10.2 cm) space between the left side of the chassis adapter module and the cabinet housing your control system. The 1756-CPR cable will not connect to the module in less than 4 in (10.2 cm) of space.
2. Connect the cable to the chassis adapter module.

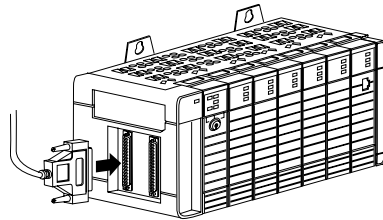

31176-M

3. Connect the cable to the redundant power supply.

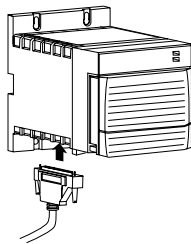

31174-M

4. Tighten the screws to hold the cable in place. Make sure you tighten the screws all the way to hold the cable in place for the life of the product.

For recommendations on how to route the wiring in your redundant power supply application, see page 14.

## Connect Solid State Relay

A solid state relay on your redundant power supplies can be connected to an input module. This connection monitors whether the supplies are functioning properly.

When using the solid state relay, you must wire a source voltage that is compatible with the input module to either contact terminal and then connect the other terminal to the input point.

The relays are closed during standard operation. The solid state relay contacts open in any of the following conditions:

- If one or both of the supplies fail. In this case, the contact open on the failed supply (ies), and the input module alerts you to the failure through the controller program.
- The connected redundant power supplies are turned OFF.

Use the graphic below to wire the solid state relay on your redundant power supply.

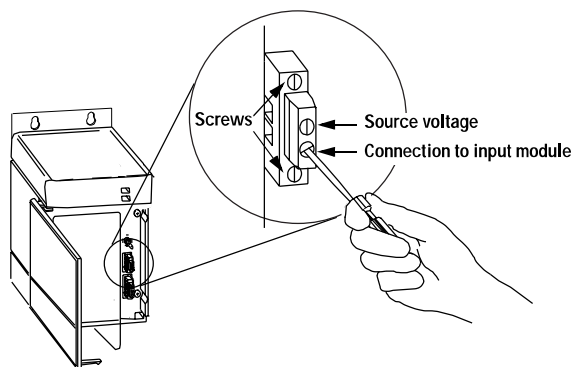

Make sure you tighten the screws on either side of the plug to make sure it is completely mated to the power supply through the life of the product.

42663

**ATTENTION**

The annunciator output is rated for resistive loads. It should not be used to drive the coil of an electromagnetic relay.



The annunciator cable must not exceed 10 meters (32.8 feet). For recommendations on how to route the wiring in your redundant power supply application, see page 14.

## Connect Power

**ATTENTION**

Turn off power lines before connecting power; failure to do so could cause injury to personnel and/or equipment. This equipment must be provided with a disconnect on each ungrounded conductor.

We recommend using #14 AWG 75°C copper wire to connect power to each redundant power supply. The diagrams below show how to connect power to the redundant power supply. Tighten the connection terminals to a torque of 7 inch-pounds (0.79Nm).

### 1756-PA75R/A (AC source wiring)

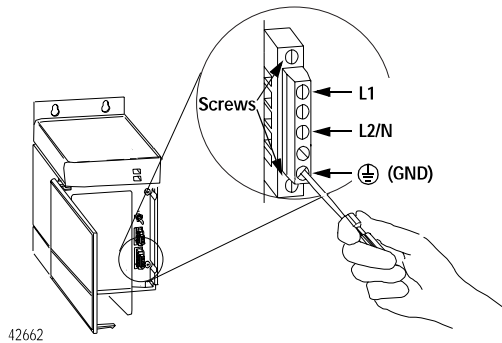

**IMPORTANT:** Tighten the screws on either side of the plug to make sure it is completely mated to the power supply through the life of the product.

Do not use unmarked terminals.

### 1756-PB75R/A (DC source wiring)

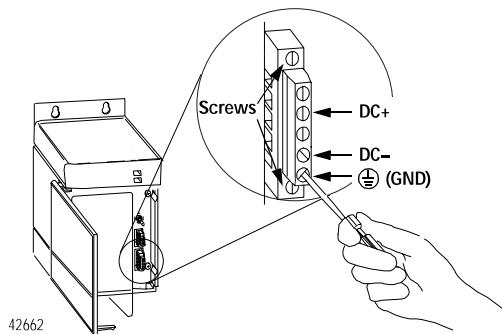

- If you are using AC source wiring, only connect wires to L1, L2/N and GND.
- If you are using DC source wiring, only connect wires to DC+, DC- and GND.

**IMPORTANT**

For recommendations on how to route the wiring in your redundant power supply application, see page 14.

## Route Line Power and Cables

Follow the guidelines below when wiring a redundant power supply.

- Never run all three lines together in any application. For example, do not run input power, output power (1756-CPR) and annunciator cable together.
- If the redundant power supply and the annunciator cable use the same input power source, you can route the power line and annunciator cable together. For example, if your application uses a DC redundant power supply and the annunciator cable is connected to a DC input module, you can route the power source line and annunciator cable together, as shown below.

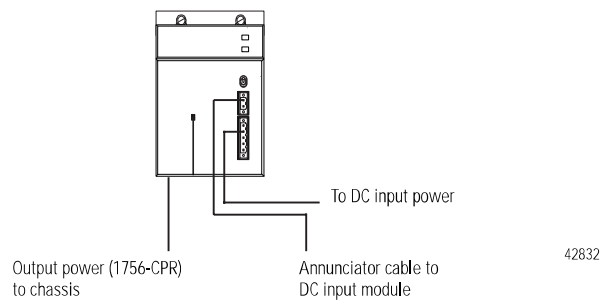

- If the redundant power supply and the annunciator cable use different input power sources, you must route the power line and annunciator cable separately. For example, if your application uses an AC redundant power supply and the annunciator is connected to a DC input module, you must route the power source line and annunciator separately, as shown below.

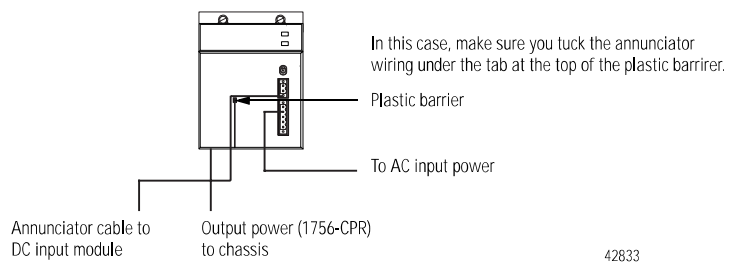

---

## Remove the Protective Label

---

**ATTENTION**



Make sure the power supply is mounted and all panel fabrication is complete before you remove the protective label. This label protects the power supply from metal shavings falling inside the power supply.

---

Pull the label off the power supply.

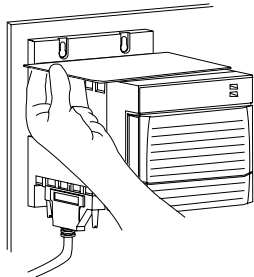

42841

## Activate the Redundant Power Supply System

After you have installed the power supplies and connected them to the appropriate chassis adapter module, flip the switch ON each supply to power the system.

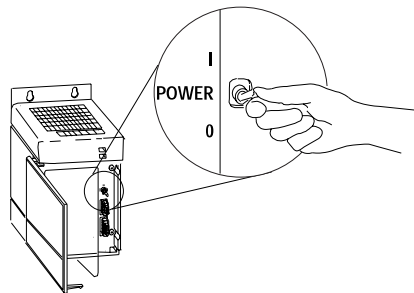

42666

## Troubleshoot with the Status Indicators

Your redundant power supply uses the following diagnostic status indicators (LEDs)

- Power - Green
- Non-red (non-redundancy) - Amber

to display possible problems with the supply. At initial power-up, the Power indicator is illuminated.

Table D explains the diagnostic indicators and how you can use them to troubleshoot your redundant power supplies.

**Table D**  
**Using Status Indicators to Troubleshoot Your Redundant Power Supply**

This combination of status indicators:	Means:	Take this action:
Power - Solid green Non-red - Off	Both supplies are operating properly. (You should see this combination on both supplies if it appears on either.)	None
Power - Solid green Non-red - Solid amber	This supply is operating properly but is the only supply providing power to the chassis adapter module.	Check the other supply.
Power - OFF Non-red - Solid amber	All possible connections are made, but the redundant power supply is turned OFF.	Turn the supply ON. If the supply does not turn ON, follow these steps: <ol style="list-style-type: none"> <li>a. Remove input power to supply</li> <li>b. Wait 15 seconds</li> <li>c. Reconnect input power</li> <li>d. Turn supply ON. If the supply still does not turn ON, replace it.</li> </ol>
Power - OFF Non-red - OFF	Any of the following conditions may apply: <ol style="list-style-type: none"> <li>1. The supply is turned OFF.</li> <li>2. Line voltage is not within the specified range.</li> <li>3. All connections are made, but input power is not supplied.</li> <li>4. All connections are made, including input power, but output cable (1756-CPR) is not connected.</li> <li>5. The supply is ON but defective.</li> </ol>	Take the appropriately numbered action for each condition: <ol style="list-style-type: none"> <li>1. Turn the supply ON.</li> <li>2. Verify that line power is in the specified range. If the indicators remain OFF, cycle power.</li> <li>3. Verify that input power is supplied and turn the supply ON.</li> <li>4. Connect output cable and turn the supply ON.</li> <li>5. Replace the supply.</li> </ol>



## Replace a Redundant Power Supply

If you must replace a ControlLogix redundant power supply, follow the steps below.

---

**IMPORTANT**

You can replace one redundant power supply while the other supply is operating in non-redundant mode without affecting chassis operation.

---

### *Remove Power Supply*

Follow the steps below to remove the supply.







1. Turn the redundant power supply OFF.
2. Disconnect line power source voltage to the supply and annunciator.
3. Remove the wiring terminal blocks.
4. Unscrew and disconnect the 1756-CPR cable from the supply.
5. Loosen mounting bolts and remove the supply.

### *Replace Power Supply*

Follow the steps below to replace a redundant power supply.

1. Slide the replacement redundant power supply over the installed screws and tighten them.
2. Install the remaining tab screw(s) at the bottom of the supply.
3. Ground the replacement supply as described on page 10.
4. Connect all cables to the new supply as described on pages 11-14.
5. Activate power as described on page 15. When you turn ON the replacement redundant power supply, the connected chassis automatically draws power from both redundant power supplies.

## 1756-PA75R/A and 1756-PB75R/A Specifications

	1756-PA75R/A	1756-PB75R/A
Location	Near ControlLogix chassis	
Input Voltage Range	85-265V ac	19.2-32V dc
Input Power	120VA, 115W	110W
Output Power	75W @ 60°C (Do not exceed 75W)	
Maximum Backplane Output Current <sup>1</sup>	1.5 A @ 1.2 V 4 A @ 3.3 V 13 A @ 5.1 V 2.8 A @ 24 V	
Hold Up Time <sup>2</sup>	@ 60 Hz: 2 cycles	20mS
Maximum Inrush Current	20A	30A
Frequency Range	47-63Hz	dc
Max. User-Supplied Overcurrent Protection <sup>3</sup>	15A	
Internal Fuse Protection <sup>4</sup>	Non-replaceable fuse is soldered in place	
Input Power Wiring	14AWG 75°C (minimum) Copper	
Solid State Relay Contact	265V ac/dc Do not exceed 50mA - Resistive only	
Annunciator Wiring	22-14AWG 75°C Copper	
Cable Assembly	1756-CPR (Length = 0.91m [3ft])	
Connector Screw Torque	7 inch-pounds (0.79Nm)	
Dimensions (W x H x D)	14.4 x 17.5 x 13.7cm (5.67 x 6.90 x 5.40in)	
Weight - approximate	1.45kg (3.2lbs)	
Environmental Conditions Operating Temperature Storage Temperature Relative Humidity	0 to 60°C (32 to 140°F) -40 to 85°C (-40 to 185°F) 5 to 95% noncondensing	
Agency Certification (when product or packaging is marked)	 UL Listed Industrial Control Equipment UL Listed Industrial Control Equipment for use in Class I, Div 2 Hazardous Locations  UL Listed Industrial Control Equipment For Use In Hazardous Locations, Certified For Canada  Certified Process Control Equipment Certified Class I, Division 2, Group A, B, C, D  Approved Class I, Division 2, Group A, B, C, D  Marked for all applicable directives  Marked for all applicable acts N223	

1. The combination of all output power (5.1V backplane, 24V backplane, 3.3 V backplane, and 1.2V backplane) must not exceed 75 W.

2. Time between input voltage removal and dc power failure.

3. Use time-delay type overcurrent protection in all ungrounded conductors.

4. This fuse is intended to guard against fire hazard due to short circuit conditions.

## Additional Information and Notes

The ControlLogix system must be mounted within a suitable enclosure to prevent personal injury resulting from accessibility to live parts. The interior of this enclosure must be accessible only by the use of a tool.

This industrial control equipment is intended to operate in a Pollution Degree 2 environment, in overvoltage category II applications, as defined in IEC publication 664A, at altitudes up to 2000 meters without derating.

## Hazardous Location Information

### The following information applies when operating this equipment in hazardous locations:

Products marked “CL I, DIV 2, GP A, B, C, D” are suitable for use in Class I Division 2 Groups A, B, C, D, Hazardous Locations and nonhazardous locations only. Each product is supplied with markings on the rating nameplate indicating the hazardous location temperature code. When combining products within a system, the most adverse temperature code (lowest “T” number) may be used to help determine the overall temperature code of the system. Combinations of equipment in your system are subject to investigation by the local Authority Having Jurisdiction at the time of installation.

---

**WARNING****EXPLOSION HAZARD**

- Do not disconnect equipment unless power has been removed or the area is known to be nonhazardous.
  - Do not disconnect connections to this equipment unless power has been removed or the area is known to be nonhazardous. Secure any external connections that mate to this equipment by using screws, sliding latches, threaded connectors, or other means provided with this product.
  - Substitution of components may impair suitability for Class I, Division 2.
  - If this product contains batteries, they must only be changed in an area known to be nonhazardous.
-

## Informations sur l'utilisation de cet équipement en environnements dangereux :

Les produits marqués « CL I, DIV 2, GP A, B, C, D » ne conviennent qu'à une utilisation en environnements de Classe I Division 2 Groupes A, B, C, D dangereux et non dangereux. Chaque produit est livré avec des marquages sur sa plaque d'identification qui indiquent le code de température pour les environnements dangereux. Lorsque plusieurs produits sont combinés dans un système, le code de température le plus défavorable (code de température le plus faible) peut être utilisé pour déterminer le code de température global du système. Les combinaisons d'équipements dans le système sont sujettes à inspection par les autorités locales qualifiées au moment de l'installation.

### AVERTISSEMENT



### RISQUE D'EXPLOSION

- Couper le courant ou s'assurer que l'environnement est classé non dangereux avant de débrancher l'équipement.
- Couper le courant ou s'assurer que l'environnement est classé non dangereux avant de débrancher les connecteurs. Fixer tous les connecteurs externes reliés à cet équipement à l'aide de vis, loquets coulissants, connecteurs filetés ou autres moyens fournis avec ce produit.
- La substitution de composants peut rendre cet équipement inadapté à une utilisation en environnement de Classe 1, Division 2.
- S'assurer que l'environnement est classé non dangereux avant de changer les piles.

#### Reach us now at [www.rockwellautomation.com](http://www.rockwellautomation.com)

Wherever you need us, Rockwell Automation brings together leading brands in industrial automation including Allen-Bradley controls, Reliance Electric power transmission products, Dodge mechanical power transmission components, and Rockwell Software. Rockwell Automation's unique, flexible approach to helping customers achieve a competitive advantage is supported by thousands of authorized partners, distributors and system integrators around the world.

**Americas Headquarters**, 1201 South Second Street, Milwaukee, WI 53204, USA, Tel: (1) 414 382-2000, Fax: (1) 414 382-4444  
**European Headquarters SA/NV**, avenue Herrmann Detroix, 46, 1160 Brussels, Belgium, Tel: (32) 2 863 06 00, Fax: (32) 2 863 06 40  
**Asia Pacific Headquarters**, 27/F Citicorp Centre, 18 Whitfield Road, Causeway Bay, Hong Kong, Tel: (852) 2887 4788, Fax: (852) 2508 1846



Publication 1756-IN573B-EN-P - May 2001

Supersedes Publication 1756-IN573A-EN-P - April 2001

PN 957555-12

© 2001 Rockwell International Corporation. Printed in the U.S.A.